



Intensidad
Intensity
Intensité



Parques de Calistenia Street-Workout Equipment Parcs Street Workout



ESP

PARQUES DE CALISTENIA

Calistreetnia es la gama de **Circuitos de Calistenia o Street Workout** de Industrias Agapito. De **fabricación robusta y antivandálica**, están diseñados para su instalación en la vía pública. Todos los aparatos de Calistenia están **certificados bajo la Norma Europea de equipos fijos de entrenamiento físico instalados al aire libre EN16630:2015**.

Los circuitos de Street Workout, que ganan popularidad día a día, ofrecen espacios de entrenamiento físico y mental, fomentando valores positivos y saludables entre los jóvenes deportistas.

Postes fabricados en acero galvanizado en caliente, de diámetro 110 mm y barras en acero galvanizado con pintura de poliéster termoendurecida. Superficies de apoyo y carteles con pictograma explicativo de uso en polietileno de alta densidad. Tornillería en acero inoxidable.

ENG

STREET-WORKOUT EQUIPMENT

Calistreetnia is Agapito Industries's **Calisthenics or Street Workout circuits range**. They are **robust and anti-vandalism manufactured** and designed for their installations in public Parks. All Calisthenics equipment is **certified under the European Standard for permanently installed outdoor fitness equipment EN16630:2015**.

Street workout circuits, which are gaining popularity day by day, offer opportunities for physical and mental training, fostering positive and healthy values among young athletes.

110 mm diameter hot-dip galvanized steel posts, galvanized steel with thermoset polyester finish paint bars. Stepping surfaces and signs with explanatory pictograms in high density polyethylene. Stainless steel bolts and screws.

FRA

PARCS STREET WORKOUT

Calistreetnia est la gamme de **Circuitos Calisthénics ou Street Workout** d'Industries Agapito. De **fabrication robuste et anti-vandalisme**, ils sont conçus pour leur installation dans les parcs et jardins publics. Tous les agrès de Calisthénics sont **certifiés par la Norme Européenne sur les modules fixes d'entraînement physique de plein air EN16630:2015**.

Les circuits de Street Workout, dont la popularité croît jour après jour, permettent une formation physique et mentale et promeuvent des valeurs positives et saines chez les jeunes sportifs.

Poteaux de 110 mm de diamètre fabriqués en acier galvanisé à chaud, barres en acier galvanisé recouvert de peinture polyester thermomodurcie. Surfaces d'appui et panneaux explicatifs avec pictogrammes en polyéthylène haute densité. Visserie en acier inoxydable.

Con rutinas entrenamiento para distintos niveles
With street-workout routines for different levels
Avec des routines d'entraînement pour différents niveaux





CIRCUITOS DEPORTIVOS / OUTDOOR SPORT CIRCUITS / CIRCUITS SPORTIFS
PARQUES DE **CALISTENIA** / **STREET-WORKOUT** EQUIPMENT
PARCS **STREET WORKOUT**

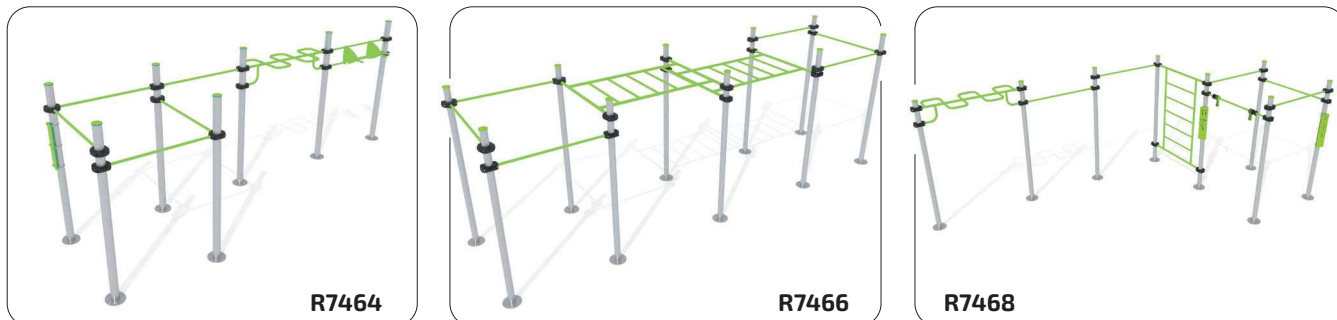
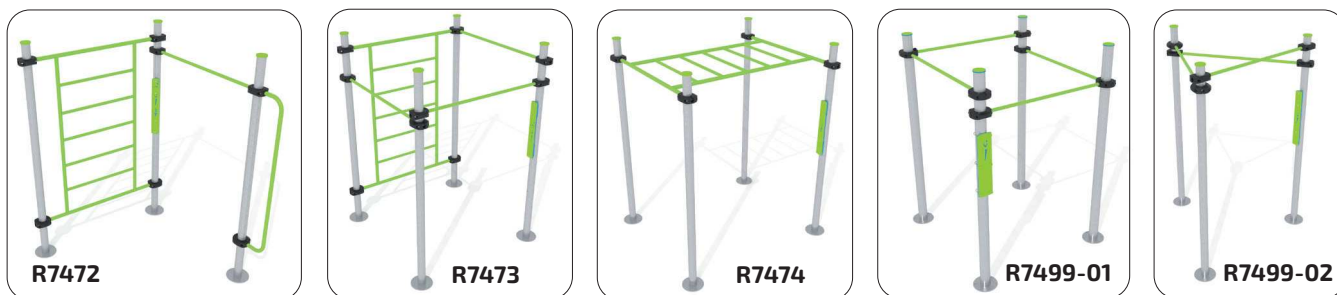
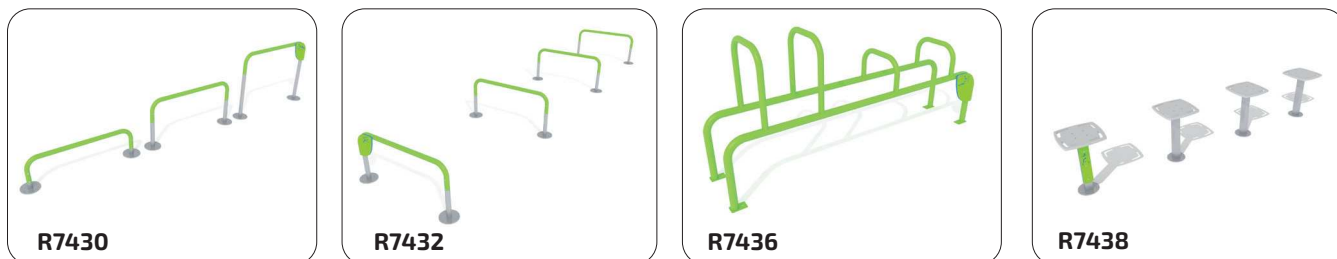

Circuitos deportivos / Outdoor sport circuits / Circuits sportifs
Parques de Calistenia / Street-Workout Equipment / Parcs Street Workout

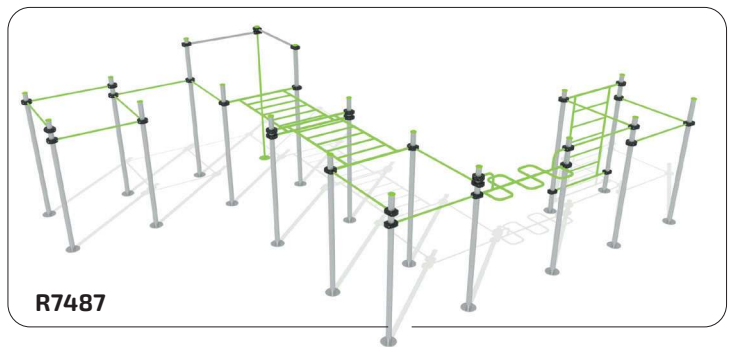
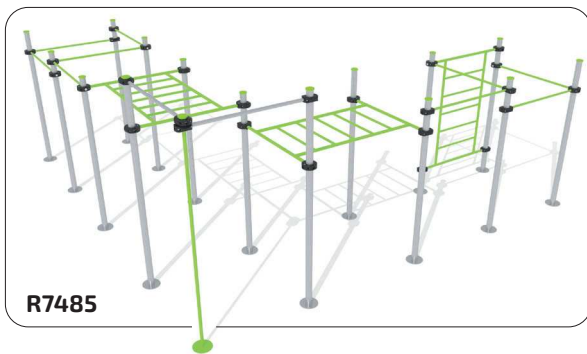
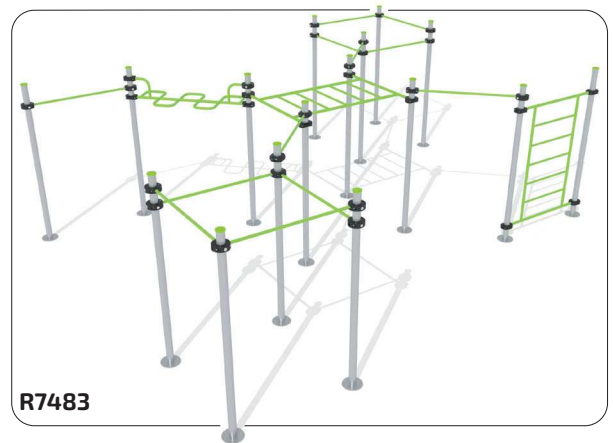
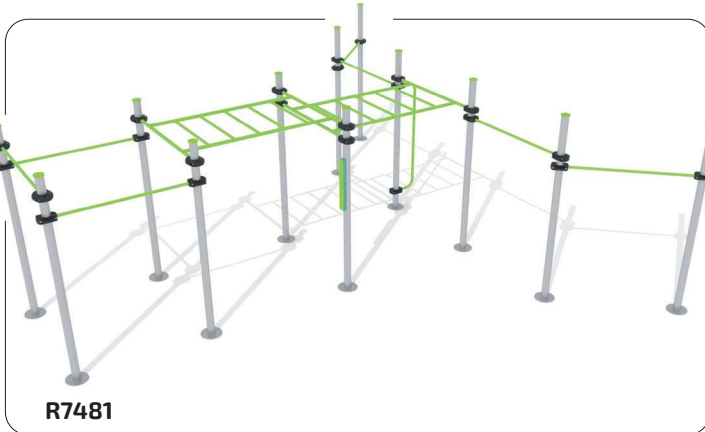
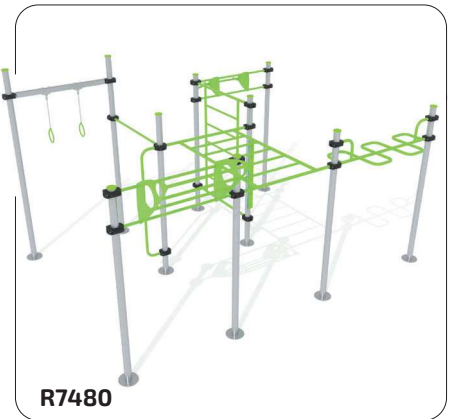
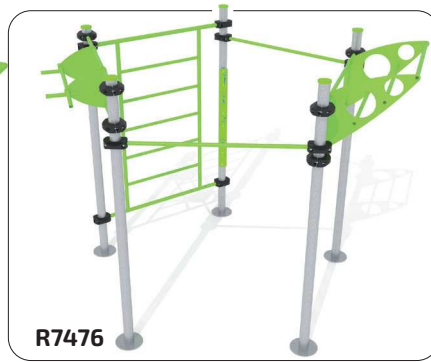
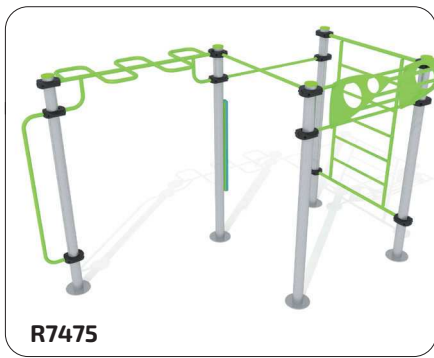

ELEMENTOS INDIVIDUALES STREET WORKOUT
 ÉLÉMENTS INDIVIDUELS POUR STREET WORKOUT
 SINGLE ELEMENTS FOR STREET WORKOUT



Barra vertical
 Flag pole. Vertical bar
 Barre verticale



Espaldera
 Wall bars
 Espalier



Barra en voladizo
 Corbel bar
 Projection bar
 Barre saillante



Barra de cristos dominadas
 Wide pull ups bar
 Barre de tractions



Anillas
 Steady rings
 Anneaux



Barra de baile
 Dancing bar
 Barre de danse



Zigzag
 Zigzag
 Zigzag



Escalador, braquiador ascendente
 Ascending brachiation
 Brachiation ascendante



900mm
 altura
 high
 hauteur

Barra paralela
 Parallel bar
 Barre parallèle



1200mm
 altura
 high
 hauteur

Barra paralela
 Parallel bar
 Barre parallèle



1,5m
 longitud
 long
 longueur

Barra fija h200-230
 Straight bar h200-230
 Barre fixe h200-230



2m
1,75m
 longitud
 long
 longueur

Barra fija extra larga
 Extra long straight bar
 Barre fixe extra large



Cuerda
 Rope
 Corde



TRX
 TRX
 TRX



Pesa Rusa
 Kettlebell
 Kettlebell

6/9/12kg



Cuerda en Suspensión
 Suspended Rope
 Corde suspendue

S/ M/ L



QR Code

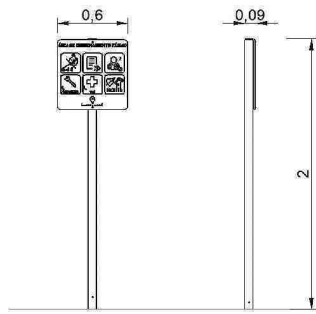

Cartel general
 General sign
 Panneau d'information générale



R7999

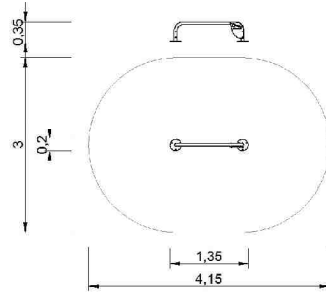

Barra de flexiones h350mm
 Push up bar h350mm
 Barre de flexions h350mm

R7412

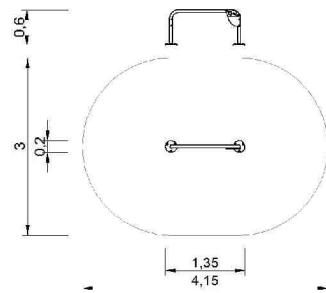

Barra de flexiones h600mm
 Push up bar h600mm
 Barre de flexions h600mm

R7414

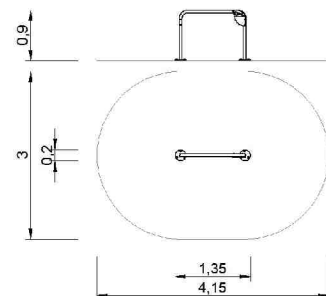

Barra de flexiones h900mm
 Push up bar h900mm
 Barre de flexions h900mm

R7416





Barra de flexiones h1200mm
 Push up bar h1200mm
 Barre de flexions h1200mm

R7418

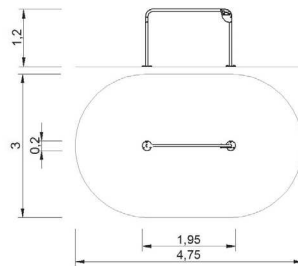

Barras paralelas h1200mm
 Parallel bars h1200mm
 Barres parallèles h1200mm

R7420

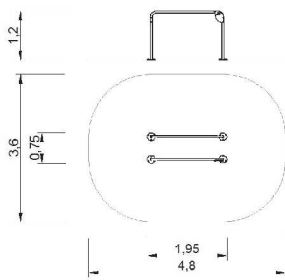

Barras paralelas triple h1200mm
 Triple parallel bars h1200mm
 Barres parallèles triples h1200mm

R7422

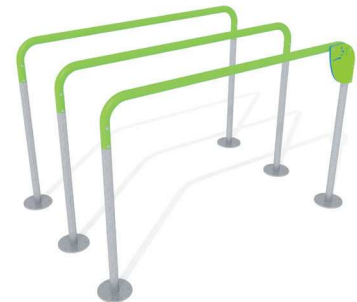
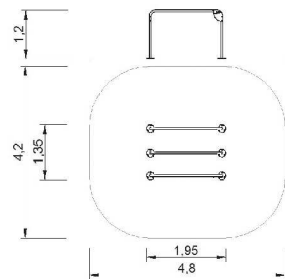

Barras paralelas h350mm
 Parallel bars h350mm
 Barres parallèles h350mm

R7424

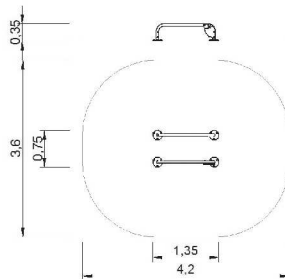

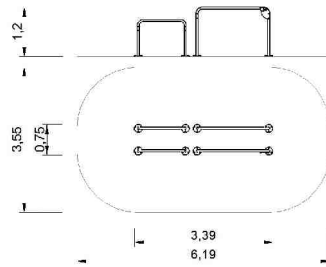
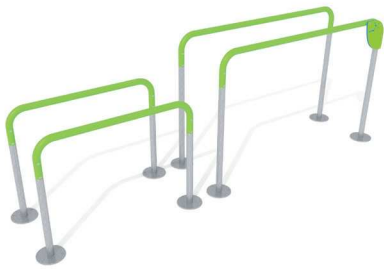
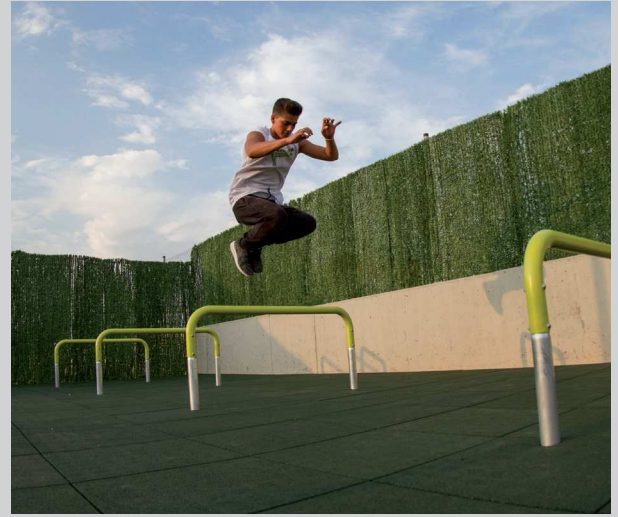

Barras paralelas 2 a 2
 2 on 2 parallel bars
 Barres parallèles 2 a 2



R7426

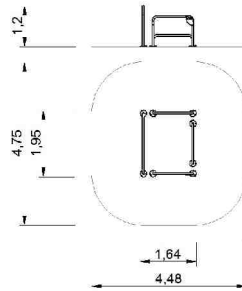
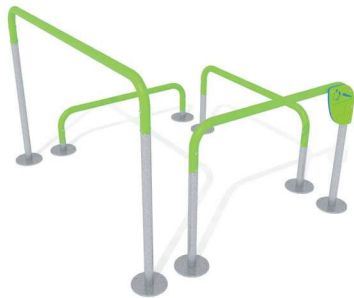

Cuadrilátero
 Quadrilateral dip
 Quadrilatère

R7428

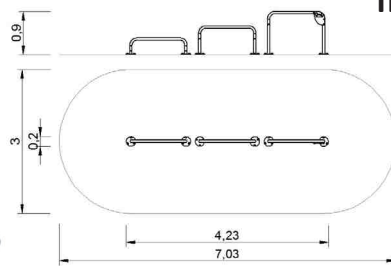
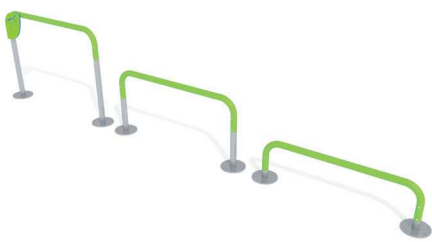

Triple barra de flexiones h350-600 y 900
 Triple push up bar h350-600 and 900
 Triple barre de flexions h350-600 et 900

R7430

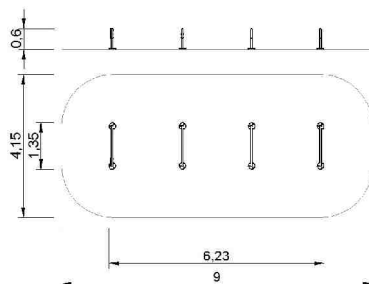

Valla de salto h600mm, 4 uds.
 Hurdle h600mm, 4pcs.
 Haie de saut h600mm, 4u.

R7432





Potro doble
 Workout desk
 Double poutre

R7436

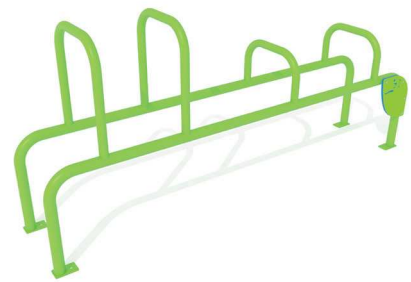
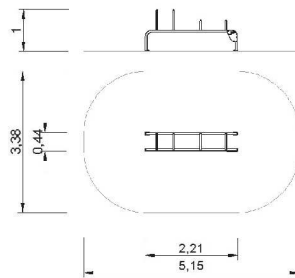

Punto de equilibrio
 Balance jump point
 Point d'équilibre

R7438

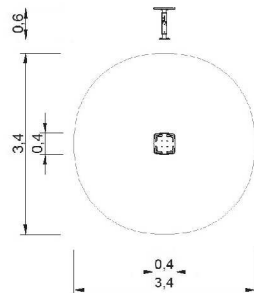

Juego bastones equilibrista
 Handstand pole
 Piquet d'équilibre

R7440

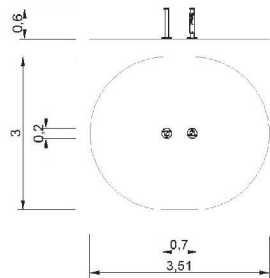

Abdominales
 Abdominal bench
 Banc à abdominaux

R7442

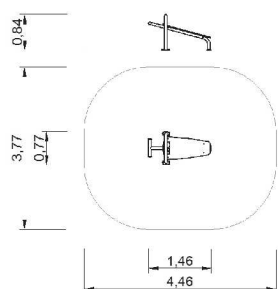

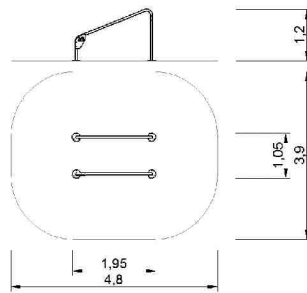

Barras paralelas Inclinas 600-1200
 Inclined parallel bars H600-1200mm
 Barres parallèles inclinées H600-1200mm



R7420D

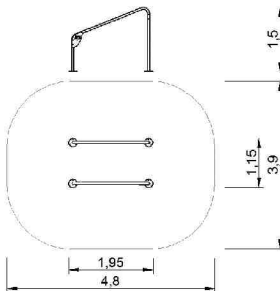

Barras paralelas Inclinas 900-1500
 Inclined parallel bars H900-1500mm
 Barres parallèles inclinées H900-1500mm

R7421D

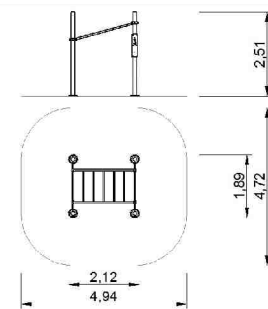

Braqueador inclusivo
 Inclusive brachiation ladder
 Échelle brachiation inclusive

R7474D

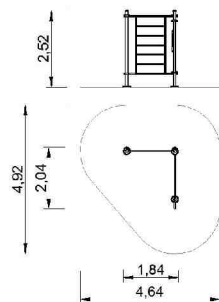

Conjunto street workout 3 postes en "l"
 Street workout set 3 posts in "l"
 Ensemble street workout 3 poteaux en "l"

R7472





Conjunto street workout 4 postes
 Street workout set 4 posts
 Ensemble street workout 4 poteaux

R7473

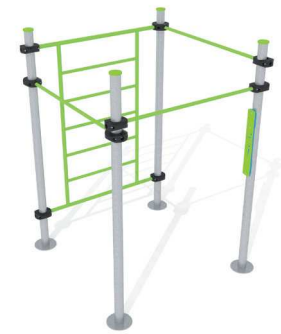
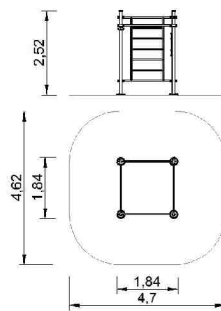

Braqueador
 Brachiation ladder
 Brachiation

R7474

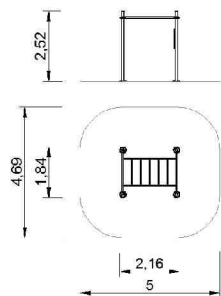

Conjunto street workout 4 postes
 Street workout set 4 posts
 Ensemble street workout 4 poteaux

R7499-01

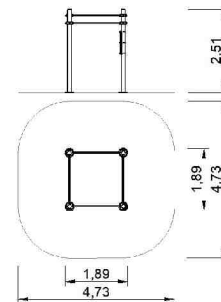

Conjunto street workout 3 postes
 Street workout set 3 posts
 Ensemble street workout 3 poteaux

R7499-02

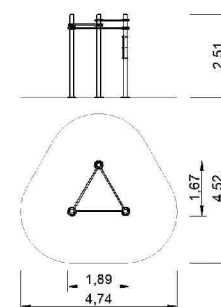

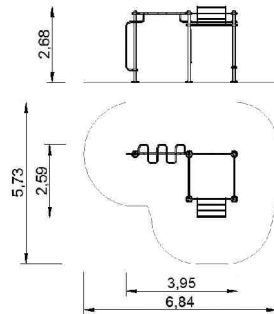
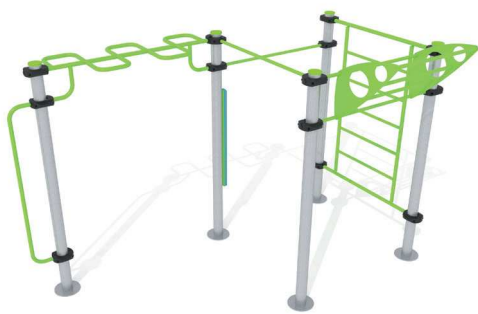

Conjunto street workout 5 postes

Street workout set 5 posts
 Ensemble street workout 5 poteaux



R7475

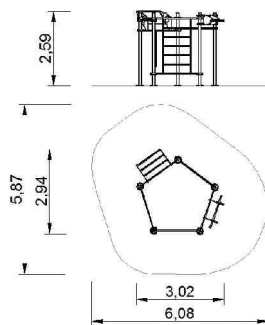
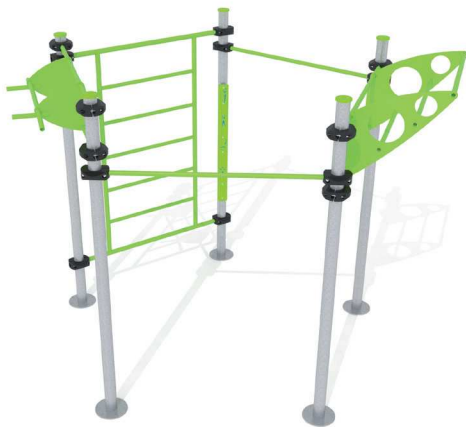

Conjunto street workout 5 pentagonal

Street workout set pentagonal 5 posts
 Ensemble street workout
 5 Poteaux en pentagone

R7476

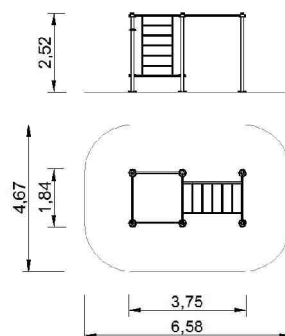
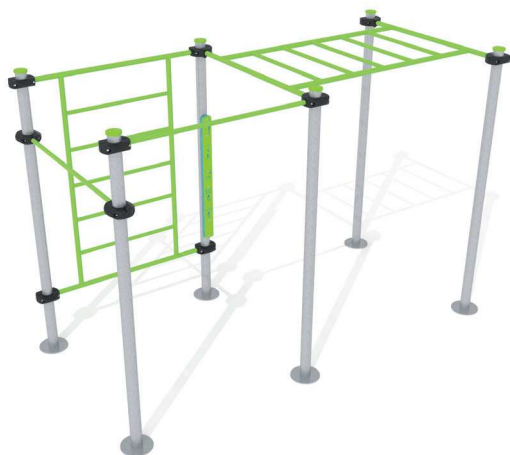

Conjunto street workout 6 postes

Street workout set 6 posts
 Ensemble street workout 6 poteaux

R7477





Conjunto street workout 7 postes
 Street workout set 7 posts
 Ensemble street workout 7 poteaux

R7464

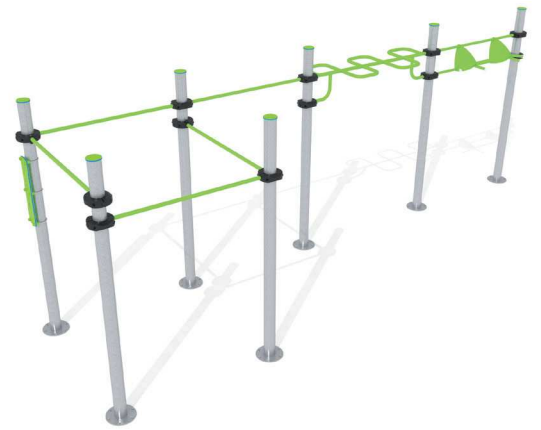
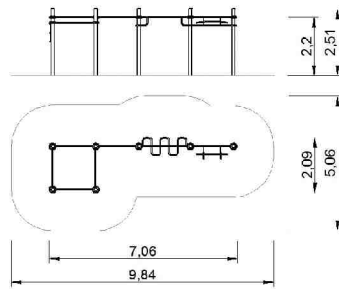

Conjunto street workout 10 postes
 Street workout set 10 posts
 Ensemble street workout 10 poteaux

R7466

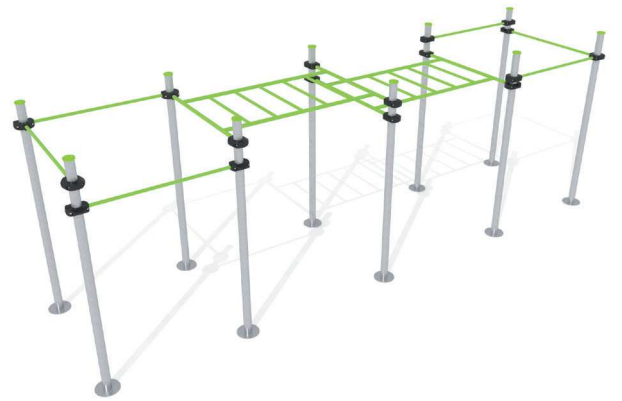
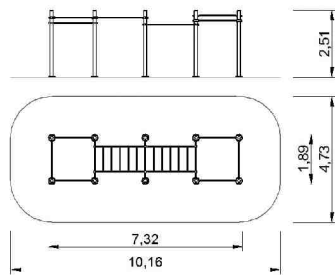

Conjunto street workout 8 postes
 Street workout set 8 posts
 Ensemble street workout 8 poteaux

R7468

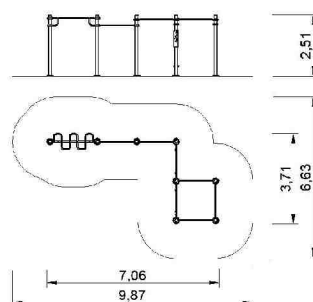



Conjunto street workout 6 postes hexagonal

Street workout hexagonal set 6 posts
 Ensemble street workout
 6 Poteaux en pentagone

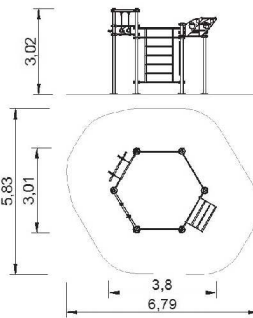

R7478



Conjunto street workout 9 postes

Street workout set 9 posts
 Ensemble street workout 9 poteaux

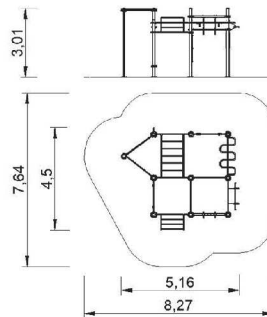

R7479

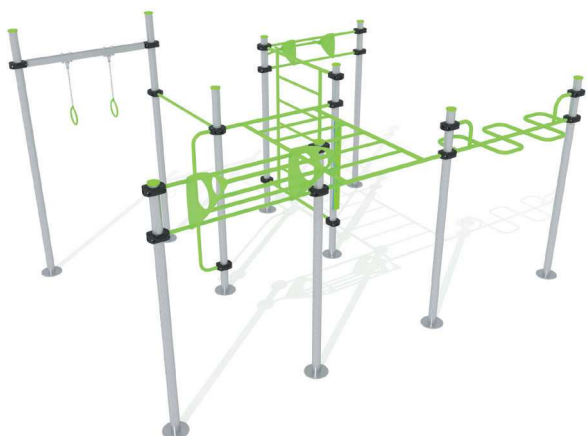

Conjunto street workout 10 postes

Street workout set 10 posts
 Ensemble street workout 10 poteaux

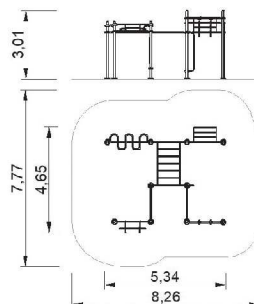

R7480



Conjunto street workout 12 postes

Street workout set 12 posts
 Ensemble street workout 12 poteaux

R7481

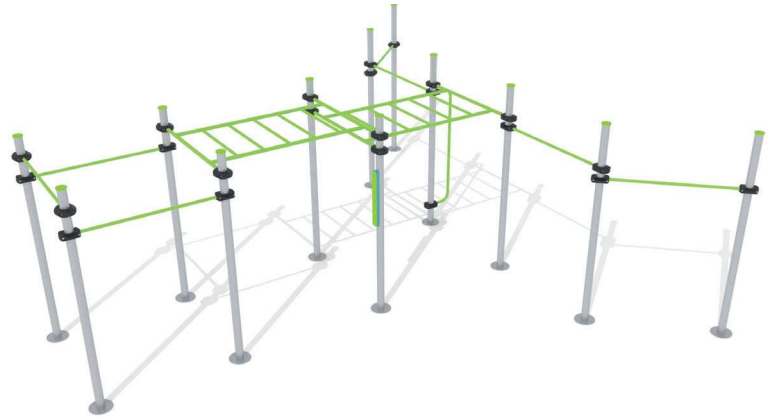
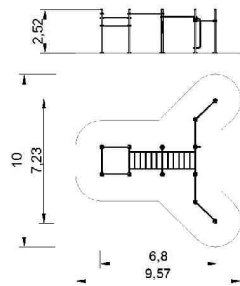

Conjunto street workout 16 postes

Street workout set 16 posts
 Ensemble street workout 16 Poteaux

R7483

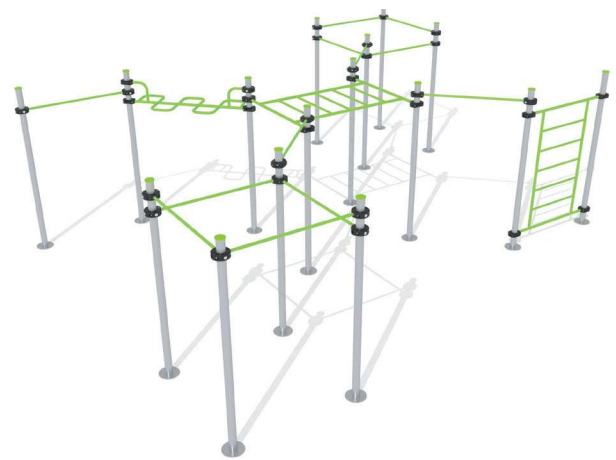
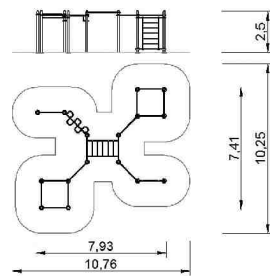

Conjunto street workout 15 postes

Street workout set 15 posts
 Ensemble street workout 15 Poteaux

R7485

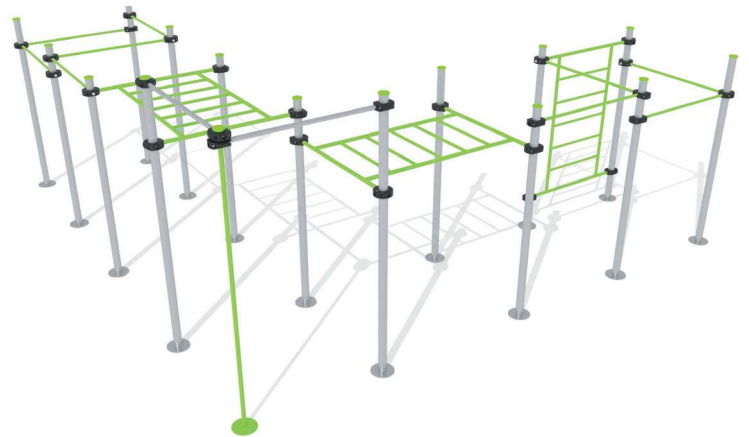
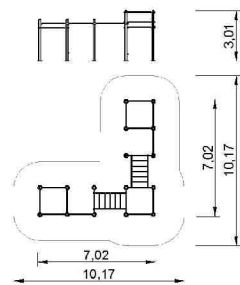

Conjunto street workout 18 postes

Street workout set 18 posts
 Ensemble street workout 18 Poteaux

R7487

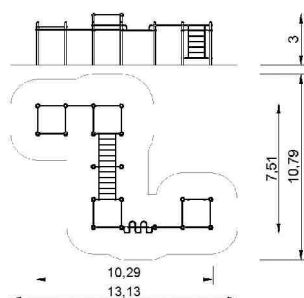

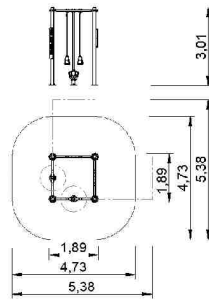

Cuadrilátero cross training con pesas rusas y cuerdas de suspensión
 Cross training box with kettlebells and suspension ropes
 Cross training quadrilatéral avec kettleballs et cordes de suspension

R7491

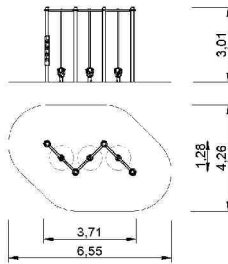

Cross training en zigzag con 3 pesas rusas
 Cross training zig zag with 3 kettlebells
 Cross training en zigzag avec 3 kettleballs



R7492

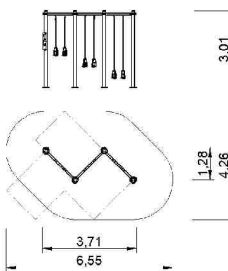

Cross training en zigzag con 3 cuerdas de suspensión
 Cross training zigzag with 3 suspension ropes
 Cross training en zigzag avec 3 cordes de suspension

R7493

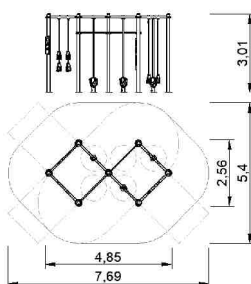

Doble cuadrilátero cross training con 3 pesas rusas y 3 cuerdas de suspensión
 Double cross training box with 3 kettlebells and 3 suspension ropes
 Double cross training quadrilatéral avec 3 kettleballs et 3 cordes de suspension

R7494





CONJUNTOS CALISTENIA / STREET WORKOUT SETS ENSEMBLES DE STREET WORKOUT

	ÁREA RECOMENDADA RECOMMENDED AREA SURFACE RECOMMANDÉE	SUPERFICIES AMORTIGUADORAS VÁLIDAS (Ver requisitos EN-16630:2015) VALID SAFETY SURFACES (See requirements EN-16630:2015) / SURFACES AMORTISSANTES VALABLES (Voir exigences EN-16630:2015)			
		Altura de caída máxima Maximum free height of fall Hauteur de chute libre max.	Arena-Grava (Espesor 300mm) Sand-Gravel (Thickness 300mm) Sable-Gravier (Épaisseur 300mm)	Suelo continuo de caucho Wet pour Sol coulé amortissant	Baldosa R4400 (Espesor 45mm) Safety tiles R4400 (Thickness 45mm) Dalles R4400 (Épaisseur 45mm)
SYDNEY AREA	64 m²	1,35 m	✓	25-50 mm	✓
SEOUL AREA	90 m²	1,45 m	✓	25-55 mm	✗
ATLANTA AREA	144 m²	1,3 m	✓	25-45 mm	✓
MONTREAL AREA	169 m²	1,7 m	✓	25-65 mm	✗
ATHENS AREA	225 m²	2 m	✓	25-80 mm	✗

SYDNEY AREA

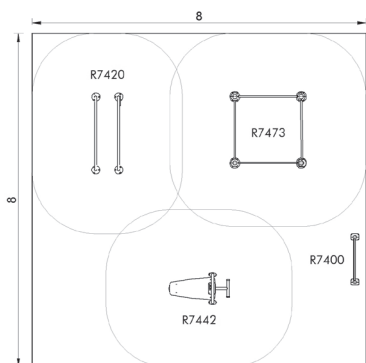

SEOUL AREA

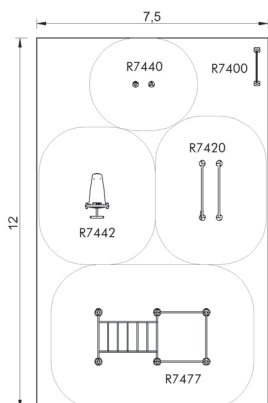



ATLANTA AREA

+14
 ANOS · YEARS · ANS

EN-16630

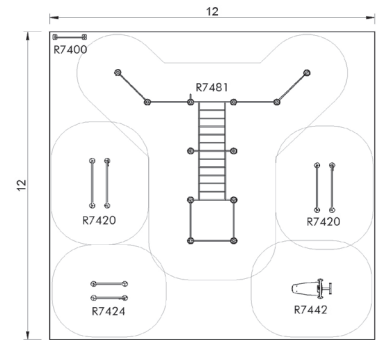

MONTREAL ÁREA

+14
 ANOS · YEARS · ANS

EN-16630

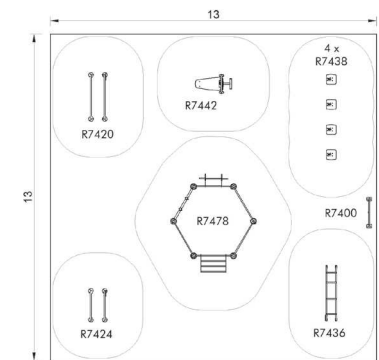

ATHENS AREA

+14
 ANOS · YEARS · ANS

EN-16630

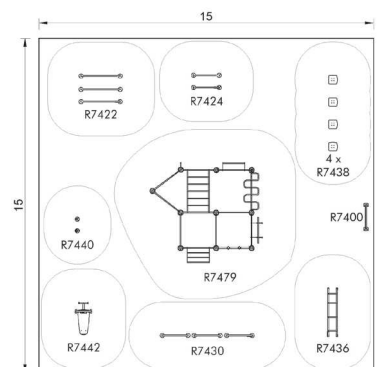



CONJUNTOS CALISTENIA / STREET WORKOUT SETS ENSEMBLES DE STREET WORKOUT

	ÁREA RECOMENDADA RECOMMENDED AREA SURFACE RECOMMANDÉE	SUPERFICIES AMORTIGUADORAS VÁLIDAS (Ver requisitos EN-16630:2015) VALID SAFETY SURFACES (See requirements EN-16630:2015) / SURFACES AMORTISSANTES VALABLES (Voir exigences EN-16630:2015)			
		Altura de caída máxima Maximum free height of fall Hauteur de chute libre max.	Arena-Grava (Espesor 300mm) Sand-Gravel (Thickness 300mm) Sable-Gravier (Épaisseur 300mm)	Suelo continuo de caucho Wet pour Sol coulé amortissant	Baldosa R4400 (Espesor 45mm) Safety tiles R4400 (Thickness 45mm) Dalles R4400 (Épaisseur 45mm)
SINGAPUR AREA	94,5 m²	1,35 m	✓	25-50 mm	✓
NEW YORK AREA	110 m²	1,4 m	✓	25-50 mm	✓
TOKIO AREA	168 m²	2 m	✓	25-80 mm	✗
SAO PAULO AREA	180 m²	2 m	✓	25-80 mm	✗
LONDON AREA	201 m²	1,4 m	✓	25-50 mm	✓

SINGAPUR AREA

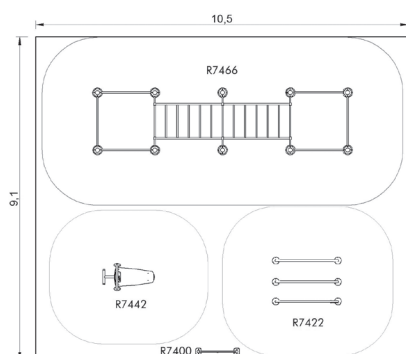

NEW YORK AREA

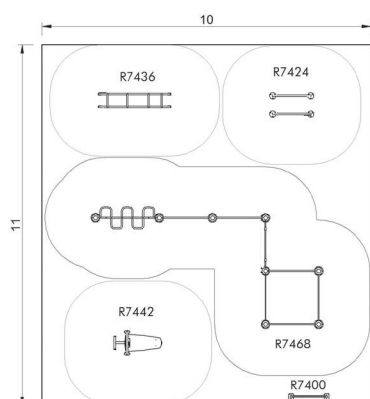



TOKIO AREA

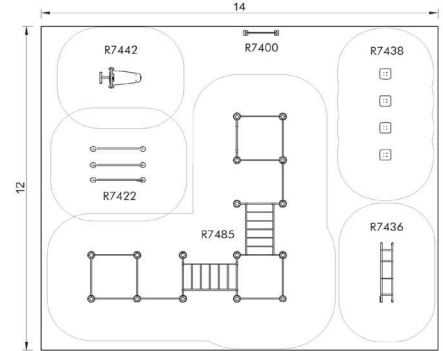

SAO PAULO AREA

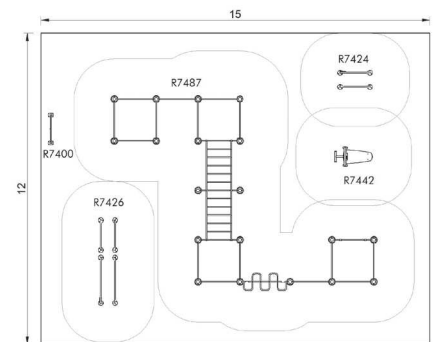

LONDON AREA

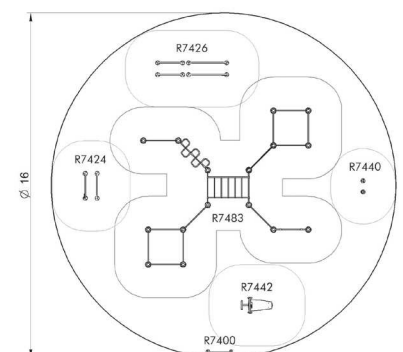

Circuitos deportivos / Outdoor sport circuits / Circuits sportifs
Parques de Calistenia / Street-Workout Equipment / Parcs Street Workout

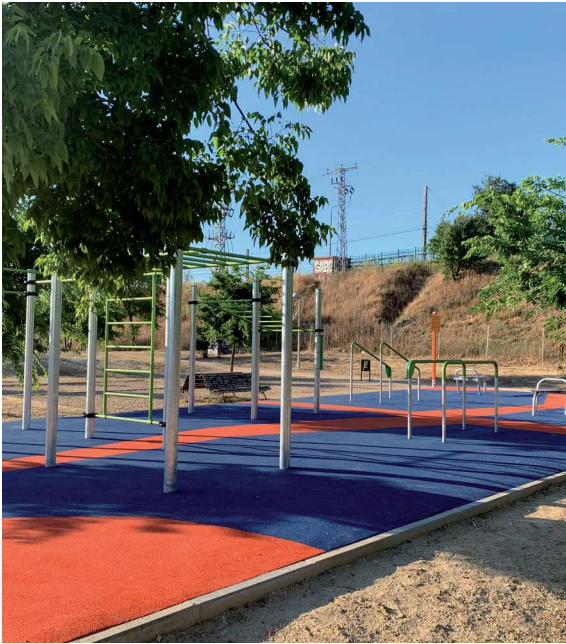

Circuitos deportivos / Outdoor sport circuits / Circuits sportifs
Parques de Calistenia / Street-Workout Equipment / Parcs Street Workout

